

Name:

Partners' Names:

Laboratory Section:

Laboratory Section Date:

Grade:

Last Revised on September 26, 2006

EXPERIMENT 7

Absolute Volt & Electrostatic Potential

0. Pre-Lab Homework [2 pts]

1. In the first part of this lab you will be using a mechanically-balanced, axially-symmetric, cylindrical capacitor to measure an absolute voltage. Each time you take a measurement, but before you read the microscope scale, you should perform a critical procedural technique. What is it, why is it critical, and how many times should you perform it? (1 pt)

2. How do you determine the electric field lines for the second part of the experiment? Electric fields are vector quantities. How will you determine the direction that they should point? (1 pt)

Name:

Partners' Names:

Laboratory Section:

Laboratory Section Date:

Grade:

Last Revised on September 26, 2006

EXPERIMENT 7

Absolute Volt & Electrostatic Potential

1. Purpose

The purpose is to calculate an absolute voltage measurement by mechanical means and illustrate the concepts of the electric field by means of experimental demonstration.

2. Introduction

A force (given by Coulomb's Law) is exerted on a particular electric charge by every other charge. The total electrical force acting on such a charge is the sum of all these forces. If a small charge were introduced to "test" it, the force on this test charge would be found to vary as it was moved around.

Considerations such as these give rise to the concept of a field. An electric field is the force per unit charge at any position in space, that is independent of the test charge and is a characteristic of the spatial distribution of charge in the region.. The electric field can be thought of as the capacity for producing an electric force on a charge. Conceptually, the electric field is well defined at any place even though there may not actually be any test charge there to experience it.

If a test charge is moved around in an electric field, the electric force will do work on it. The static electrical force of Coulomb's law is a conservative force. That is, the work done moving between two points is independent of the path taken. This suggests another useful concept, *electric potential*. The potential difference between two points is the work per unit charge that would be done by the electric field in moving a test charge between them.

This laboratory experiment should help the student gain a concrete grasp of these abstract concepts and facilitate understanding of capacitance and the connection between force, distance and energy in the context of electrical phenomena.

In the first part of this experiment, you will relate an electrical potential to mechanical quantities using an indirect method to make an absolute voltage measurement. This method,

through clever design, avoids the worst of the systematic errors from which a direct Coulomb's Law experiment suffers and yields more precise results. In the second part, you will investigate static electric fields and map out their equipotential surfaces.

3. Laboratory Work

3.1 Absolute Measurement of Voltage

Introduction

An absolute measurement of electrical potential difference by mechanical means is a way to learn about electrical quantities and relate them to mechanical ones that are already known.

The study of electricity and magnetism normally begins after a thorough introductory study of mechanics. The first important electrical relationship encountered is Coulomb's law, which says that the force acting between two point charges is proportional to their magnitudes and inversely proportional to the square of the distance between them. Once the constant of proportionality has been chosen the unit of charge has in principle been defined for that system of units (i.e. mks). Then, in order to measure charge one would simply set up two identical point charges a known distance apart, measure the force between them and then use Coulomb's law to get the magnitude of the charges.

But making a direct and accurate measurement of Coulomb's law is not readily feasible. The required point charges are not available, and the distribution of charges on conducting spheres (such as one might try to use in practice) is not uniform. The distribution of charge depends in a complicated way on the position of all local objects, conducting or non-conducting, charged or not charged.

Fortunately, a practical way exists to determine an electrical quantity in terms of force, by making an "absolute" measurement, using a method based upon capacitance.

The Concept of Capacitance

Since the charge on an electrical conductor distributes itself so as to form an equipotential, there is a certain value of electrical potential associated with each conductor. And, because electrostatic fields superimpose, these potentials will be linearly related to the charges on the conductors. The concept of capacitance describes the coefficients of these relationships, which are determined only by system geometry.

In a system of two conductors carrying opposite charges of magnitude Q , this relationship is simply,

$$C = Q V \qquad \text{Equation 7.1}$$

where V is the voltage (potential difference) between them, and the coefficient C is their mutual capacitance. A simple example is the parallel plate capacitor, which has a capacitance in air (neglecting edge effects) of,

$$C = \frac{\epsilon_0 A}{d} \text{ (m.k.s.units)} \qquad \text{Equation 7.2}$$

$\epsilon_0 (= 8.854 \times 10^{-12} \text{ C}^2/\text{N}\cdot\text{m}^2)$ is the dielectric constant of free space.

In a capacitor one plate has positive charges on it and the other has negative. These charges attract, so the plates of such a capacitor exert attractive forces on each other. This force can be obtained, given the charge distribution on the charged capacitor, by integration. However, it is also possible to approach this problem from the point of view of the principle of virtual work. The stored electrical energy of such a system is,

$$U = \frac{1}{2}(CV^2) \quad \text{Equation 7.3}$$

Since this energy changes as the geometry (and hence C) changes, it must require work to

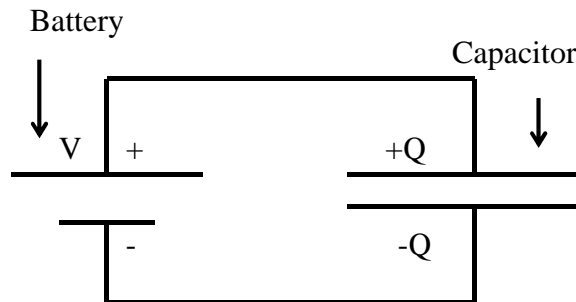

Figure 7.1

move the plates of a capacitor. It is the force F_e that the plates of the capacitor exert on each other that does this work. Thus, if C depends on a single dimension z the magnitude of the force between the electrodes (i.e., the rate at which work is done per unit displacement) in the direction of that variable, assuming V is constant, is,

$$F_e = \frac{dU}{dz} = \frac{1}{2}V^2 \frac{d}{dz}C(z) \quad \text{Equation 7.4}$$

In the parallel-plate case this is,

$$F_e = \frac{\epsilon_0 A}{2d^2}V^2 \quad \text{Equation 7.5}$$

Note the quadratic dependence of the force on the voltage and that the constant of proportionality, apart from an electrical physical constant, is purely geometric. Therefore, if the force between the plates can be measured, the potential difference V can be calculated immediately. From the above example the voltage is calculated from,

$$V = \left[\frac{F_e 2d^2}{A\epsilon_0} \right]^{1/2} \quad \text{Equation 7.6}$$

This is the principle on which this experiment is based. However, for practical reasons the capacitor will be two concentric cylinders rather than parallel plates. The axis of the cylinders will be in the same direction as the force (+z). Of course, the capacitance between the two cylinders will be different from the capacitance of the parallel plate, the example shown above, but capacitance depends only on system geometry. This is discussed below.

The Experimental Apparatus

The apparatus shown in Figure 7.2 is designed for measuring the axial force in the vertical direction between two concentric aluminum circular cylinders. The potential difference is determined across these two cylinders where up to 3,000 V is applied. The outer cylinder of the capacitor is fixed in the semicircular ends of two Lucite plates. The inner cylinder, which must be quite uniform and light in weight, is made from a cleaned beverage can.

This inner cylinder moves vertically, supported by a thin shaft constrained by two bearings. These bearings must run freely; so they must be kept clean. If a bearing begins to rub or grab it can be washed out with alcohol and then lubricated with a small single drop of spindle oil. The lower end of the shaft is supported by a hollow float partially submerged in water. Distilled water with a few drops of Eastman Kodak Photo-Flo 200 wetting agent will reduce surface tension. The fully submerged main body of the float, a ping-pong ball (of unknown compressibility) provides most of the buoyancy required to support the shaft and its load. The submerged portion of the glass tube connecting the ball to the shaft supplies the rest.

The net vertical force on the movable part of the experiment is,

$$F = F_e + F_b + F_g \quad \text{Equation 7.7}$$

F_e is the electrical force between the cylindrical capacitors, non-zero when a potential is applied; F_b is the *upward* buoyancy force of the ping-pong ball, and F_g is the *downward* force of gravity. The idea is for F_b and F_g to almost cancel each other so that F_e dominates. When a potential is applied, the electrical force will be balanced by any change in the buoyant force, ΔF_b .

The (vertical) equilibrium position is set by the water level in the beaker and the small weights (brass or steel nuts) in the weight pan. The weights should be used to adjust the immersion of the float so that the surface of the water is level with the center of the rod. The water level should be adjusted so that the can clears the top bearing by about a centimeter.

The system will be displaced from equilibrium by any force between the cylinders. The position of the system is observed through a low-power microscope directed at an optical target on the shaft.

The can is connected to ground via the bearings; the outer cylinder is connected to the potential source through a protective (high voltage) resistance of several tens of mega-ohms.

Although this high voltage is exposed, the resistor prevents any significant current from flowing; it is not dangerous, although it may be uncomfortable if touched. **Therefore, do not touch the can, which could be at 3000 Volts.**

The can and cylinder overlap for a length much greater than the radial spacing between them, and the cylinder extends well beyond the upper end of the can. Under these conditions the change in capacitance produced by a small axial position shift s will, to a very good approximation, be given simply by,

$$\Delta C = \kappa s \quad \text{Equation 7.8}$$

where κ is the capacitance per unit length of a long cylindrical capacitor and given by,

$$\kappa = \frac{2\pi\epsilon_0}{\ln\left(\frac{r_2}{r_1}\right)} \quad \text{Equation 7.9}$$

where r_1 is the radius of the beverage can, and r_2 is the radius of the cylinder. These equations are valid because the electrical field distribution in most of the overlap region is essentially invariant axially; and also the end effects will be quite small due to the favorable geometry (the cylinder extends well beyond the can above and the can extends well beyond the cylinder below).

Accordingly, for a potential difference V between the electrodes, the change in energy storage with displacement may be written,

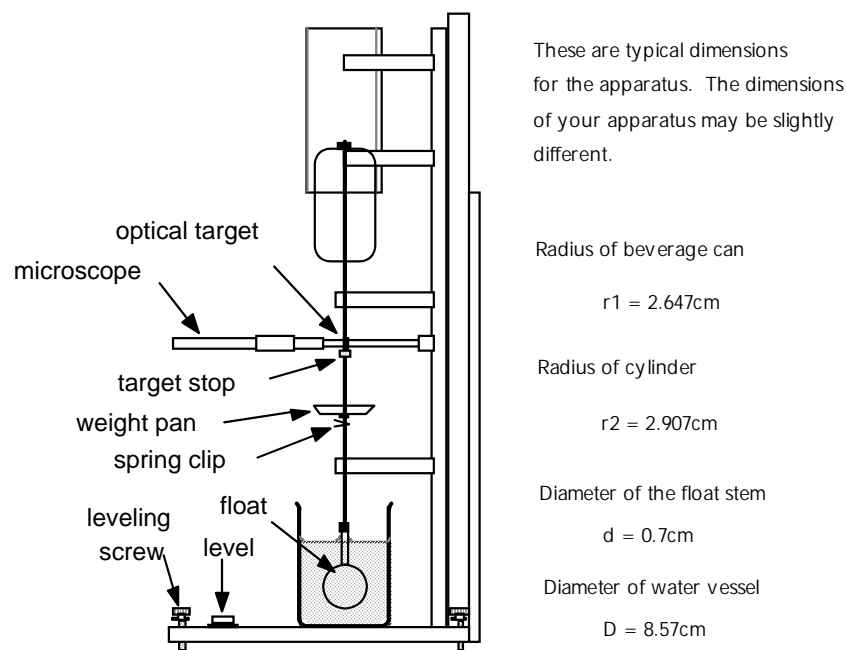

Figure 7.2

$$\Delta U = \frac{1}{2} \Delta C V^2 = \frac{1}{2} (\kappa s) V^2 = \frac{\pi \epsilon_o}{\ln\left(\frac{r_2}{r_1}\right)} V^2 s \quad \text{Equation 7.10}$$

By the principle of virtual work, the force is the derivative of U with respect to s . Therefore,

$$F_e = \frac{dU}{ds} = \frac{\pi \epsilon_o}{\ln\left(\frac{r_2}{r_1}\right)} V^2 \quad \text{Equation 7.11}$$

is the force acting on the inner can due to electrical effects.

The system will float at equilibrium where all the forces due to gravity, buoyancy and electrical effects balance out. The system is constructed so that the buoyancy of the fully submerged ping-pong ball mostly cancels out the constant force of gravity. Thus changes in the electrical forces due to the potential of the cylinder will be balanced by the changes in buoyancy due to the changed level of the float in the water.

These changes in the buoyant forces arise from changes in the water displaced by the float, which is that due to the stem (small glass tube) since the ball is always submerged. The weight of this displaced water is,

$$\Delta F_b = \pi \rho g \frac{d^2}{4} \left[1 + \frac{d^2}{D^2 - d^2} \right] s \quad \text{Equation 7.12}$$

where ρ is the density of water and d is the diameter of the float stem. The factor in brackets accounts for the small absolute level change of the water in the beaker (D is the beaker's diameter) due to the displacement of the float system.

Since ΔF_b is small for the thin tubing, the apparatus is very sensitive to the magnitude of the electrical force, and this can be estimated from the observed displacement of the shaft and the known geometry of the float system.

Combining the above expressions gives the applied voltage,

$$V^2 = \frac{\ln\left(\frac{r_2}{r_1}\right)}{\epsilon_o} \rho g \frac{d^2}{4} \left[1 + \frac{d^2}{D^2 - d^2} \right] s \quad \text{Equation 7.13}$$

in terms of the displacement and the parameters of the system. (Note that $\rho = 1000 \text{ Kg/m}^3$ in mks units.) The right hand Equation 7.13 depends only on mechanical quantities.

Procedure

CAUTION: Do **NOT** touch the can. Although the available power is too small to be dangerous, potentials of several thousand volts are involved here so touching the cylinder may be uncomfortable. Also, if it gets dirty the experiment may fail.

1. Check to see if the water level is about halfway up the glass stem of the float; if not, add or remove weights to make it so. Check to see that the can clears the upper bearing properly (about 1 cm). If it is necessary, add or remove water.

For accurate and reproducible measurements the shaft must be able to freely assume its proper position. Even when the bearings are well aligned and the shaft is essentially vertical, bearing friction will interfere with the necessary free movement. This can be overcome by setting the system spinning by gentle use of thumb and forefinger on the shaft. Steady your hand by resting it lightly on the bearing support while doing this. Make sure your hands are clean when spinning the shaft, wash them if necessary.

2. Fiddle with the apparatus to become familiar with it. Try spinning the shaft gently using (clean and dry) thumb and forefinger. Once started, spinning should persist for five or ten seconds and should gradually die out rather than come to a sudden stop. Check to see if your apparatus behaves this way; if not the bearings need to be cleaned and you should get your TA to help.

Important: Every time you make a change you must spin the shaft to overcome the friction. Do this at least –twice- to confirm that you are obtaining an accurate reading.

3. Remove the microscope from the apparatus and hold it up to the light. Observe the scale on the lens of the microscope. The scale is 6mm long with large divisions of 1mm and small divisions of .1mm. It may be helpful to hold the microscope a few inches away from your eye. Replace the microscope into the apparatus.

3. Focus the microscope so that the target and scale can both be seen clearly while looking through the microscope. Focusing is achieved by moving the microscope in or out. If necessary, reset the optical target by loosening the small screw on the target stop, centering the target on the scale, then retightening the small screw. Spin the shaft and observe how the target settles into position. Repeat, checking for consistency.

4. Note that by knowing the spacing of the target marks (about 4mm), you can extend your range of measurement by sighting on one or the other. In other words, if the target mark you were sighting leaves the field of view of the microscope, you can use the next mark and the distance between the marks to calculate the displacement. Measure the actual length of your target so you can do this (see Figure 7.3).

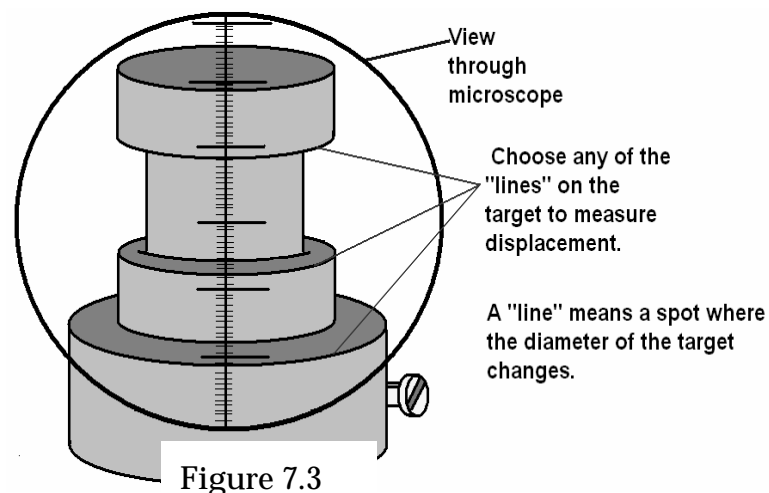

Figure 7.3

Calibrate Displacement vs. Voltage

4. Apply five different voltages as indicated by the power supply meter to the apparatus, ranging up to near 3000V. Suggested voltages are: 0, 1000, 2000, 2500, 3000 Volts. Again spin the shaft at least twice after changing the voltage to make sure you are getting the consistent measurements. Measure the displacement of the optical target mark from one voltage to the next. Record your displacement readings for each voltage change in Table 7.1 located in Section 4.1.

Measure a Voltage Using the Theoretical Sensitivity

5. Set your power supply to some intermediate voltage (i.e. 2200 Volts). Record this value in Section 4.1. We will treat this measurement as the “unknown” voltage, and try to determine it in two different ways: first from the method in *Step 4* and second (the ‘null’ method) from *Steps 9 – 11*.

6. Switch the power supply off (to ground) and note the microscope scale reading.

7. Then switch back on the power supply and record the microscope scale reading. Subtract to get the displacement, s . Record the displacement data in Table 7.2.

8. Repeat this measurement several times, recording your measurements in Table 7.2. Then average the measured values to determine s_{avg}

Measure a Voltage Using the “Null Method”

9. Without changing the power supply voltage (i.e. use the same “unknown voltage”), find another value for the applied voltage by use of a “null method”. With the power supply off or disconnected, note a "zero" point on the microscope scale. □

10. Then apply the voltage from the power supply (i.e. 2200 Volts).

11. Keeping careful track, add masses until the zero point has been passed, then interpolate to find the mass corresponding to scale zero. Calculate the force F_{null} due to this mass and record this force in the space provided in Section 4.1.

-----Switch off all POWER when you are done.-----

3.2 Electric Field Mapping

Introduction

In this experiment you will investigate the electric potentials set up by electrodes that cause currents to flow in conductive sheets. You will be able to map out the equipotential contours and find the electric field lines for several configurations of electrodes.

The apparatus (see Figure 7.4) includes a board, which holds a sheet of special paper with a conducting graphite surface, a battery, test electrodes and a voltmeter.

The paper is imprinted with grid lines for reference purposes. It is mounted on the base with the spring clips contacting the silver electrodes. The battery is connected to the binding posts to apply a potential difference (voltage) between the electrodes.

Apparatus Function

In a conductor, such as the silver electrodes, even small electric fields will cause large amounts of charge to move in such a way as to tend to cancel out the field. Thus charges will distribute themselves on the electrodes so as to make them equipotential surfaces. The field between the electrodes will be that appropriate to the resulting distribution of charges.

The graphite surface of the paper, on the other hand, has a much higher resistance than the electrodes. Small currents will tend to flow along the electric field lines (i.e. between the potential differences) set up by the charged electrodes but these will not be sufficient to significantly disturb the field pattern. The voltmeter measures the potential difference between the location of the hand probe and the location of the stationary probe. Thus, by finding points between which the voltmeter measures zero, you can map out contours with the same potential.

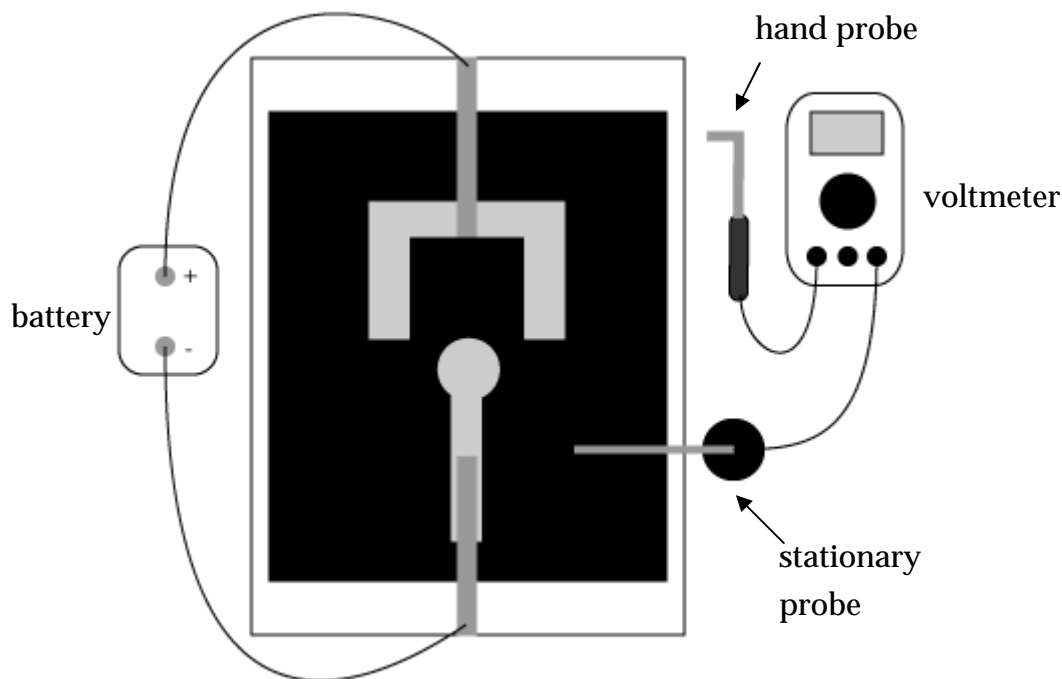
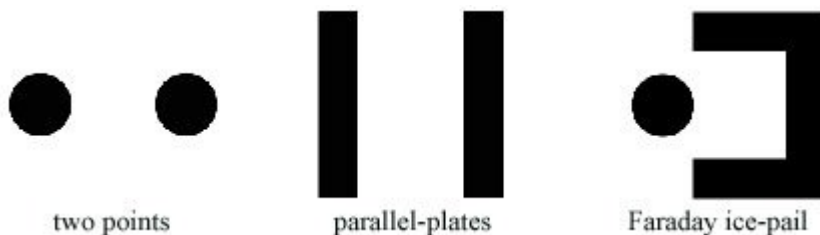

Figure 7.4. Field Mapping Apparatus

Procedure

Previous to investigating the electrode patterns, complete Question 7 of Section 4.2. Then, use the following procedure to map out the fields for the three different electrode patterns. These are:



Tabulate your measurements and results for each on one of the worksheets available at the end of the lab report.

1. Start by tracing the electrode configuration on your sheet and marking the positive electrode.
2. The voltmeter is connected to two field probes. Place the stationary probe at a reference position somewhere between the two electrodes.
3. Mark this position on your data sheet.
4. Then move the point of the hand probe over the paper to find a place giving a zero or “null” reading on the meter.
5. Mark this equipotential point on the graph. In order to ensure good contact, it may sometimes be necessary to gently agitate the probe tips a bit.
6. Without moving the stationary probe, locate a whole series of null points across the paper with the hand probe and mark the position of each on the data sheet.
7. When you have found enough points to draw a smooth line through them, do so. This is an equipotential contour and the potential between any points on this line is zero.
8. Now move the stationary probe to a new position (not on your old contour) and map out another contour of constant voltage by repeating steps 2-7.
 - a. Map out at least four equipotential lines for the two-point arrangement.
 - b. Map out at least four equipotential lines for the parallel plates arrangement. Be sure you probe beyond the edges of the plates to notice interesting patterns there.
 - c. Map out at least four equipotential lines for the Faraday Ice-pail pattern. Two of these lines should examine the inside of the “pail.” Sketch as many

equipotentials as is necessary to show its interesting structure. In the Faraday's ice-pail pattern, start your examination by putting the stationary probe near the bottom of the "pail."

9. The electric field is everywhere perpendicular to the equipotentials. Sketch in with dashed lines on your data sheets examples of how the electric field lines (lines of force) must run. Be sure to do this in the interesting parts of the pattern. Remembering that the electric field is a vector, indicate with arrows the direction associated with the electric field lines.

10. BE SURE TO DISCONNECT THE BATTERY AND TURN OFF THE VOLTMETER WHEN YOU ARE DONE!

REFERENCE:

H.W. Fullbright, "A Simple and Inexpensive Teaching Apparatus For Absolute Measurement of Voltage", American Journal Physics, v.61, pp. 896-900, Oct. 1993.

Name:

Partners' Names:

Laboratory Section:

Laboratory Section Date:

Grade:

Last Revised on September 26, 2006

EXPERIMENT 7

Absolute Volt & Electrostatic Potential

4. Post-Laboratory Report [18 pts]

4.1 Analysis for the Absolute Volt experiment [9 pts]

Table 7.1

Voltage (V)	s (mm)

Table 7.2

s (mm)

Unknown

Voltage _____

S_{avg} _____

Record F_{Null} _____

1. Make a plot of the data from Table 7.1 of Displacement vs. Volts² (note the squared Voltage!) Draw a best-fit straight line and measure its slope. Show your calculation and include units. Include a label with units identified for each axes. (2 pts)

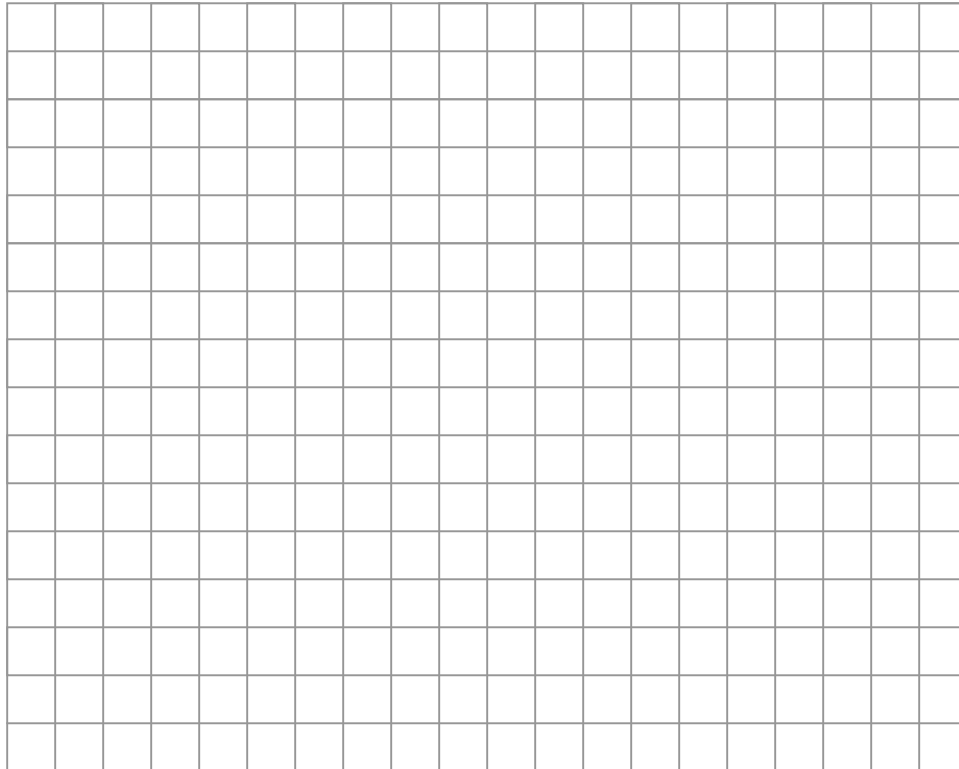

2. Using the slope found in the graph above (in mm/V²) and the average value of displacement from Table 7.2, calculate the “unknown” voltage. Compute the percent error using this value and the known value. (1 pt)

3. Calculate the “unknown” voltage from theory using Equation 7.13 and your system's geometric parameters (see Figure 7.2 - use mks units). Compute the percent error using this value and the known value. Compare this percent error to your percent error from Question 2. (2 pts)

4. Using Equation 7.11 and the balancing force, F_{Null} , calculate the “unknown” voltage again. Here only stability of the zero point is required; the buoyant force does not appear in the calculation. (1 pt)

5. What is the limiting experimental parameter for measuring an unknown voltage in each measurement? (In other words, what mechanical parameter has the greatest uncertainty?) (2pts)

displacement measurement?

null method measurement?

6. Finally, which method of measurement is more reliable? Why? Be specific. (1 pt)

4.2 Analysis for the Electric Field Mapping Experiment [9 pts]

7. Draw the electric field lines you would expect for the point charge below. Identify two arbitrary regions of the electric field and label which one is stronger. State how can you determine this from the field lines (1pt)



4.2.1 Two-Point Pattern Data Sheet

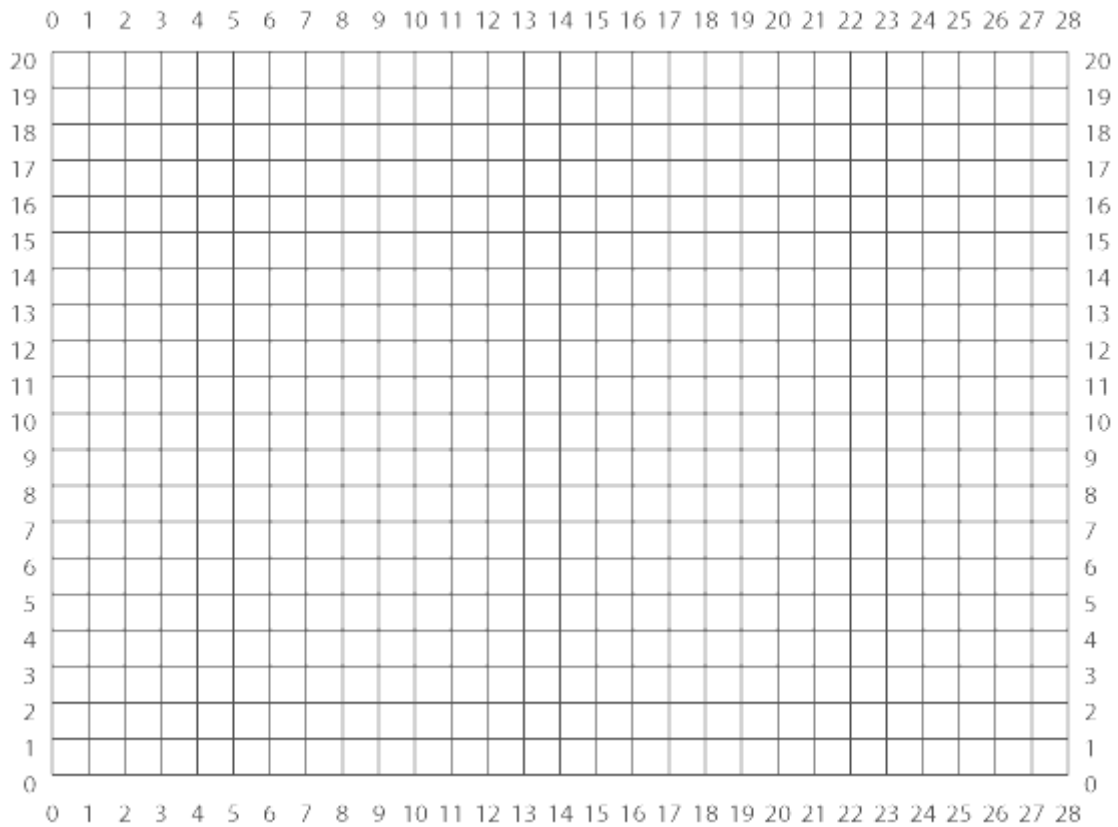

8. Sketch in the electric field lines according to your measured mapping of equipotential surfaces. Be sure to include arrows to show the direction of your field lines. (1 pt)
9. In which region(s) would the electric force on a test charge be the largest? Why? (1pt)

4.2.2 Parallel Plate Pattern Data Sheet

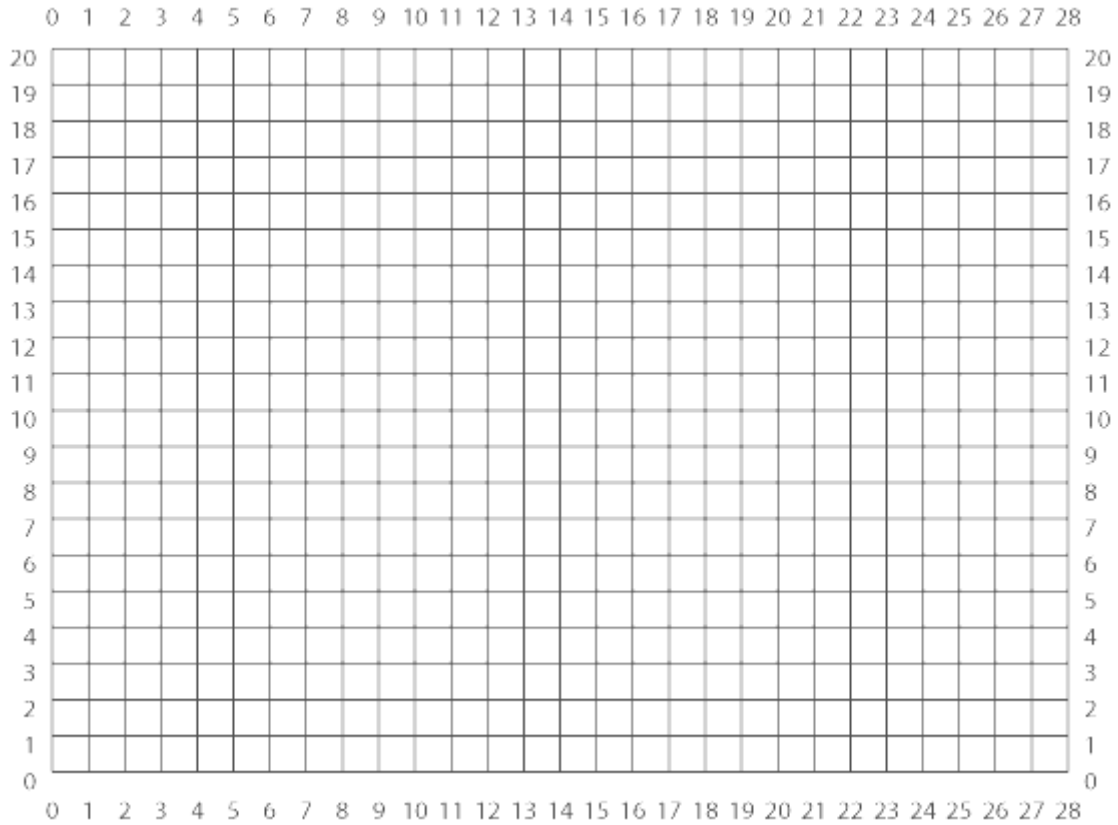

- 10.** Sketch in the electric field lines according to your measured mapping of equipotential surfaces. Be sure to include arrows to show the direction of your field lines. (2 pts)

- 11.** Describe the trajectory of a *positive* unit charge if it were introduced midway between the plates with a velocity directed parallel to the plates. Draw a figure if you desire. (1 pt)

4.2.3 Faraday's Ice-Pail Pattern Data Sheet

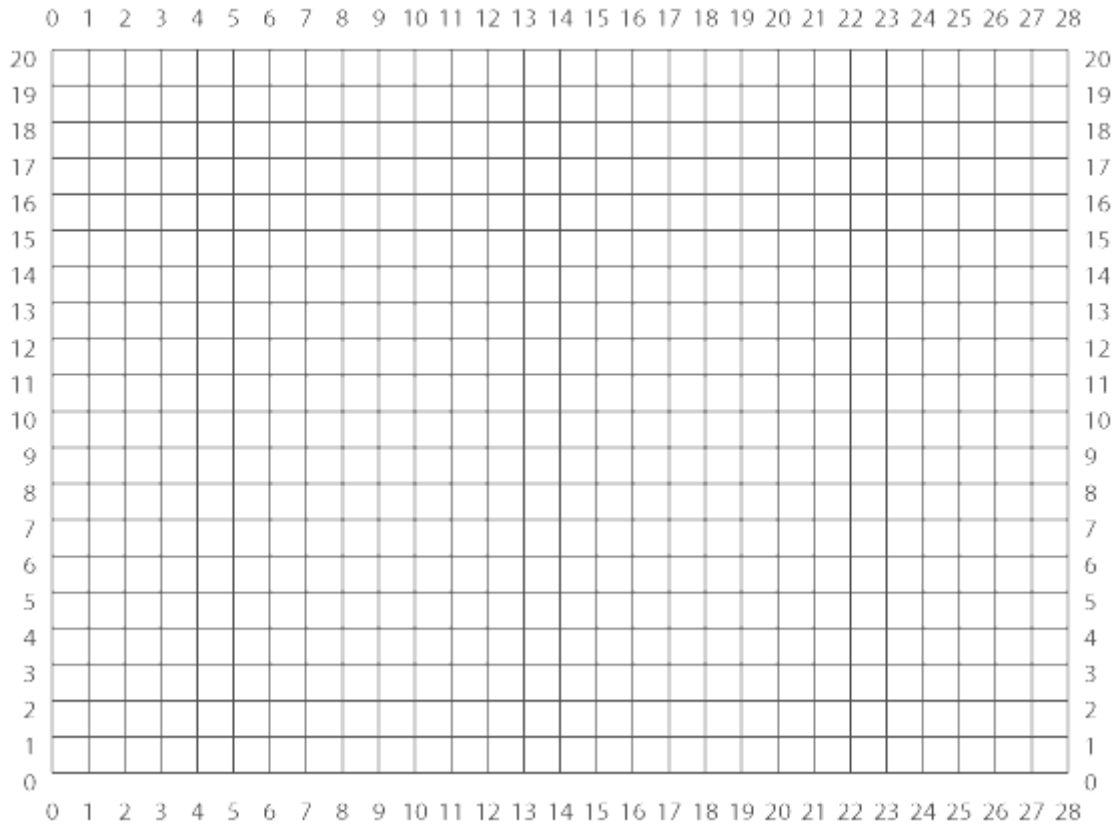

- 12.** Sketch in the electric field lines according to your measured mapping of equipotential surfaces. Be sure to include arrows to show the direction of your field lines. (2 pts)
- 13.** Is the electric field inside the pail larger or smaller than outside? Why? (1pt)